

TAPERED REFRACTORS

Models 200, 205, 210 and 215

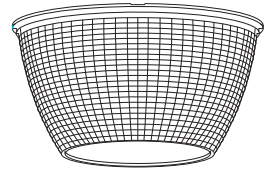

Model 200



**Models 200, 205,
210 and 215**

8.12" high
15.9" diameter

STREET, ROADWAY AND AREA
LIGHTING APPLICATIONS

Model 215 Type V
Efficiency: 62.2%
IES Classification: Type V, Semi-cutoff,
Arc Tube Voltage Rise = 1.8

Materials: Acrylic and polycarbonate

Description

These 15.9" diameter refractors are designed for use with up to 400W HID lamps in roadway, area and industrial lighting applications. Open bottom refractors provide relamping and maintenance ease, while closed bottom refractors provide additional protection for the light source. Models 200 (closed bottom) and 205 (open bottom) are impact resistant polycarbonate refractors for use in areas where breakage is a concern. Models 210 (closed bottom) and 215 (open bottom) are ultraviolet stabilized acrylic refractors for high efficiency operation in general applications.

Lamp Data

When using Models 205 and 215 (open bottom versions) with a vertically burning lamp, up to 400W HID lamps may be used. When using Models 200 and 210 (closed bottom versions) up to 250W HID lamps may be used. Thermal tests should be conducted on each luminaire design with the proposed light source in its selected position to confirm lamp size and suitability, and to predict service life of the refractor.

Ordering Information

Please call 877-257-5841 for price and delivery. Typical lead time is four to six weeks.

Service Life

The service life of acrylic refractors is virtually unlimited when used within the recommended temperature limit. Polycarbonate refractors are subject to yellowing especially when used with high ultraviolet output light sources; this effect is enhanced at high temperatures.

Notice

A.L.P. Lighting Components, Inc. assumes no responsibility for suitability of luminaires and applications. The use of our molded products at excessive temperatures with high UV output light sources will cause degradation of the material. Information regarding the use of lenses and refractors with Metal Halide lamps can be found in the Products/Technical Resources section of our web site at www.alplighting.com. * See second page for important UL information.



A.L.P.
LIGHTING COMPONENTS, INC.
WEB SITE: WWW.ALPLIGHTING.COM

 **LEXALITE**

Models 200, 205, 210 and 215

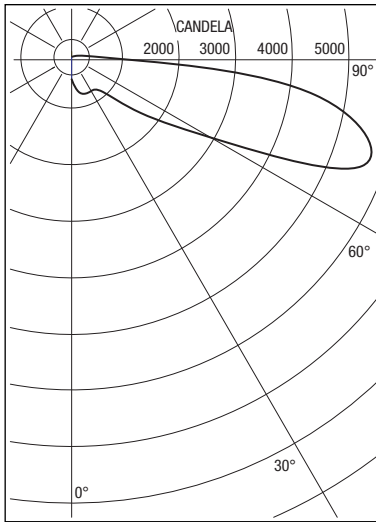

Photometrics:

All models are available in symmetrical IES Type V distribution for general area lighting. Model 215 V, when used with a 250W HPS lamp, in typical post-top applications, produces 5623 candela at 70° above nadir as shown at left. (ITL37326) An asymmetrical IES Type II distribution is available and may be used in various roadway or interior aisle lighting applications. Luminaires have been designed with specific off-axis lamp centers to produce IES Type I, III or IV distributions for special lighting applications. Please call for details. Individual luminaire performance depends on the lamp center position and the reflector design chosen. Each luminaire design should be individually tested for proper classification. Please visit our web site for additional photometric data.

Report Number: ITL37326
 Total Luminaire Efficiency = 62.2%
 IES Classification: Type V, Semi-cutoff
 Arc Tube Voltage Rise = 1.8

Accessory

LiteLid®

For applications requiring reduced uplight and improved downward efficiency, use our Model 415 LiteLid; a patented, perforated, aluminum reflector, which mates with this component. The LiteLid component should be utilized in light pollution sensitive areas.

Materials

See the LexaLite® brand price list for current part numbers and material offerings. Up-to-date and detailed material specifications can be found in the Products/Technical Resources section of our web site at www.alplighting.com.

When using acrylic Models 210 and 215, the surface temperature of the refractor should not exceed 80°C. When using polycarbonate Models 200 and 205, the surface temperature of the refractor should not exceed 90°C.

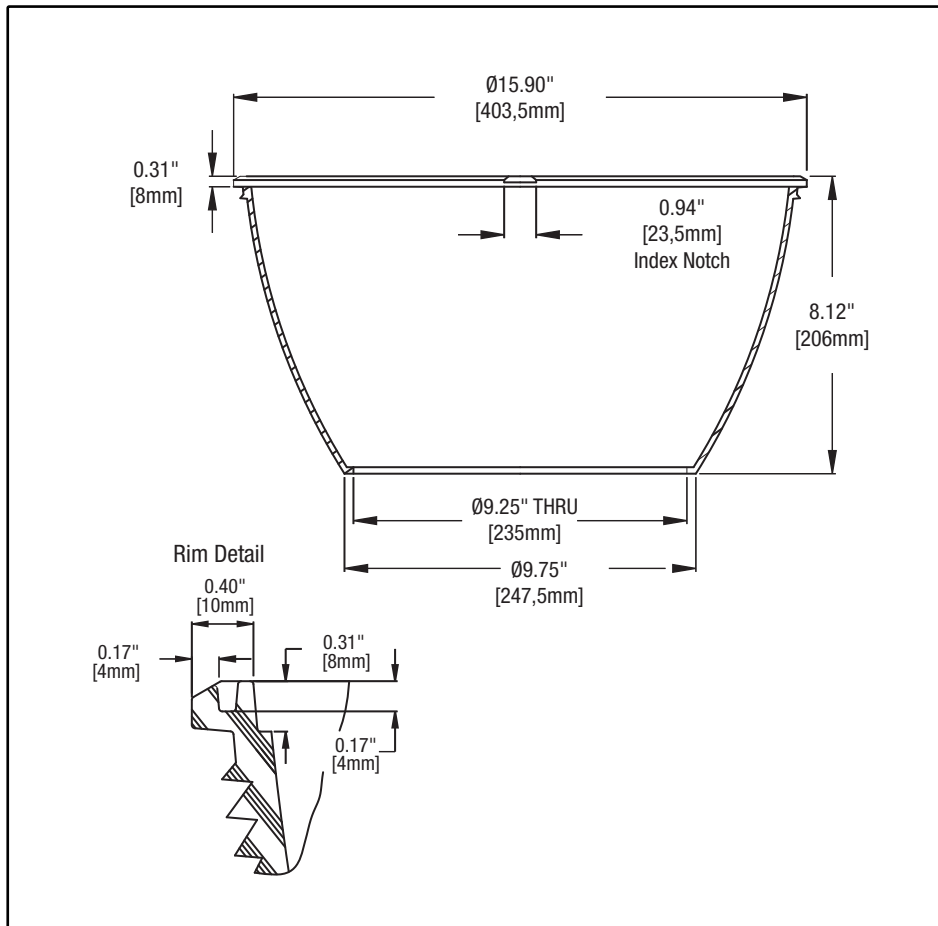

This drawing is for reference only. Actual part dimensions will vary. Customer is urged to review actual samples to confirm fit and function. All specifications and dimensions are subject to change without notice.

***Effective June 30, 2010, lenses associated with this product will no longer be UL recognized components. A.L.P. LexaLite recommends the use of open rated lamps with any polymeric lens. These lenses should not be used as arc retention devices.**